

# PHANTOM<sup>®</sup>

## Specialized produce travelling column machine

*Quality / Excellent / High efficiency*



*TCM Series*

ARCO CHEER ENTERPRISE CO., LTD.



# Travelling Column Machine

## DUPLEX 38B+C

- Built-in high-speed spindle with tilt head (B axis) is a processing tool.
- Choice with C-axis to achieve the best results processing.



B axis (Tilt head)



B axis angle at 90°



C axis

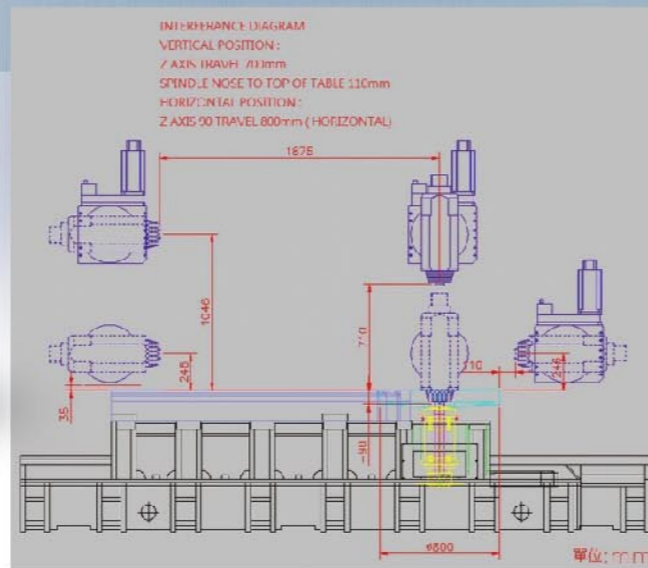

# Travelling Column Machine

## DUPLEX 38B+C

### Swiveling Table : (C axis)

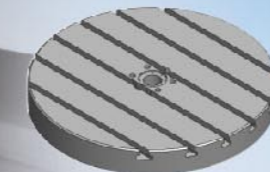

A Type

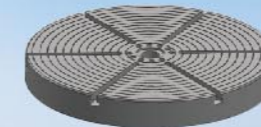

B Type

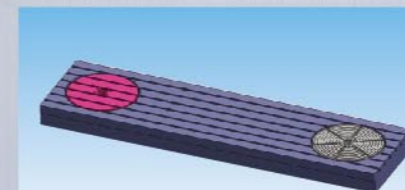

Build-in rotary table (Option)

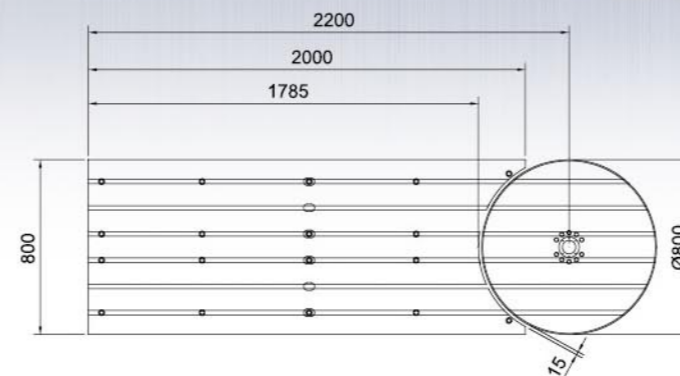

ITEM	MODEL	DUPLEX 38B+C
Fixed table		800 x 1770 mm
Working area		800 x 1770 mm
X axis travel		3000 mm
Y axis travel		800 mm
Z axis travel VERTICAL position		600 mm
Z axis travel HORIZONTAL position		800 mm
Spindle nose to top of table VERTICAL position		110mm
Spindle center to face of column		810 mm
Spindle taper		BT40 or BBT40
Spindle speed		15000 rpm ( Build-in type )
Spindle motor		33 Kw
Tilting head		±120°
X / Y / Z axis rapid		12 / 24 / 24 M / min
Cutting feed rate		1 - 10000 mm / min.
Tool magazine capacity ( arm type )		24
Max. tool diameter		150 mm
Max. tool length		300 mm
Max. tool weight		7 Kgs
Position / 300 mm		± 0.01
Repeatability		± 0.01
Tool change time T-T		2.5 secs
Max. table load		1200 Kgs
Coolant capacity		550 L.
High floor to top of table		970 mm
X axis transmission		Dia. 63 mm grade C3 P. 10
Y / Z axis ball screw & grade		Dia. 40 mm P. 12 C3
X / Y / Z axis slide way		Roller type linear rail
Foot print L x D x H		7200 x 3900 x 3200 mm

### STANDARD EQUIPMENT

- Auto power off M30
- Coolant equipment pump & tank
- Powerful chip flash nozzle
- Leveling screw and plates
- Auto lubrication system
- Spindle air blast
- Rigid tapping
- Heat exchanger for cabinet
- RS-232 Interface

- Work and alarm lamp
- Fluorescent light
- Tool box with necessary tools
- Full enclosed splash guard
- Auger screw
- Interlock switch
- 15000 rpm spindle & chiller
- Hydraulic unit

### OPTIONAL ACCESSORIES

- Chip conveyor with bin
- Linear scale
- Transformer ( for fanuc & mitsubishi system )
- CTS 20 bar
- CTS 20 bar with paper filter
- Tool probe



# Travelling Column Machine

## TCM-466/486/666/686/866/886

### FEATURES

- X axis is equipped with mechanical dual gear box that provides backlash free performance.
- Y & Z axis are with high-speed precision and low noise ball screw dia. 40 mm grade: C3.
- X, Y & Z axis are with linear roller rail.
- TCM's provide rigidity machining to make longer bars such as aluminum, rail, construction equipment, aerospace components, shaft, etc.
- TCM's allow longer and strong fixed table (4m, 6m, 8m) to be mounted together with the base.
- TCM's divide many work stations with 4<sup>th</sup> axis rotary table to achieve work efficiency.

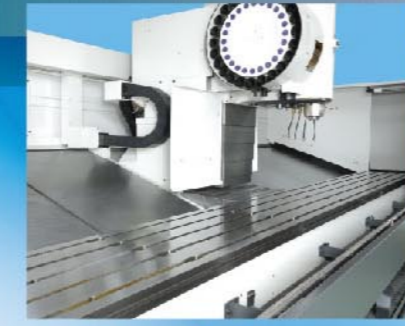

Slant Telescopic Cover

- X axis is with slant type telescopic cover.
- Chips fall directly into the base so that chip evacuation can be done with ease.

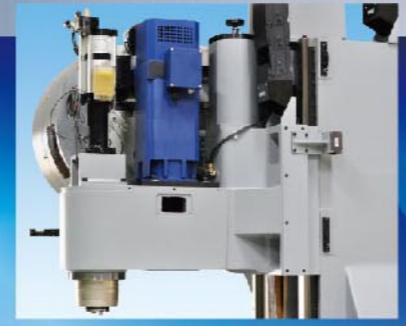

Strong Head Housing

- Round arc design of housing assures more solid to eliminate vibration.
- Strong column structure ensures stability to bear weight of head housing and keep spindle excellent accuracy.



Vertical retractable metal type cover



# Travelling Column Machine

## TCM-466/486/666/686/866/886

### FEATURES

- Spindle can be choice with BT50 with 6000 rpm belt drive (OP.)
- BT40 12000 rpm and BT50 8000 rpm belt drive with chiller (OP.)
- BT40 & BT50 also direct drive available (OP.)
- Two speed gear box available (OP.)



Multiple work stations



Vertical retractable metal type cover



8 M Base and table





# Travelling Column Machine

TCM-466/486/666/686/866/886

X axis with dual gear box

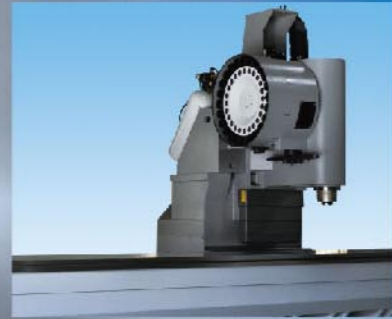

ATC Interface & column

- The ATC base together with centralized column made by cast iron in one-piece construction not only ensure machine longevity and stability but also provide best quality and performance to complete jobs.



Dual gear box, pinion & installation

- X axis is transmitted by mechanical dual gear box and joint with servo motor.
- Dual gear box is installed in horizontal position under the middle of saddle so that X axis can move smoothly to eliminate vacillation problem when the machine stops suddenly .



- The gear box peak output torque is 1150 Nm, normal input speed 600 – 2400 rpm, maximum input speed up to 4000 rpm.
- The helical pinion hardness HRC62°, right angle version, ratio 1:21.

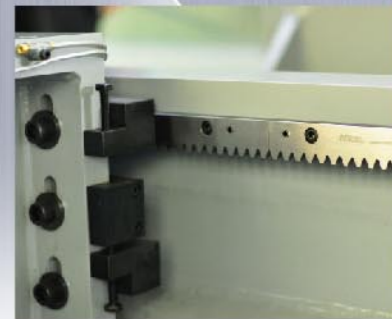
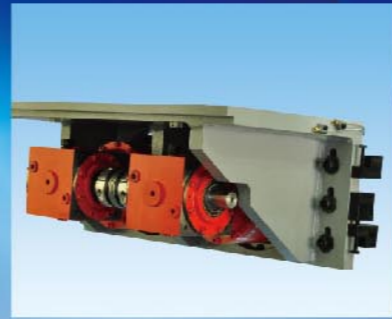

Precision helical rack

- The precision helical rack is hardened and ground also surface .
- The hardness is up to HRC60 - 62°.

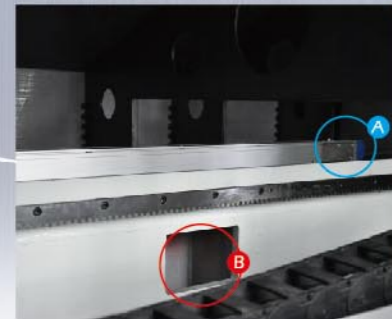

Linear scale & extra leveling placing in the middle of base

- A.Linear scale can be mounted on the base (optional).
- B.Extra leveling is placed in the middle of the base. It provides more stability to do machining so as to avoid vibration.

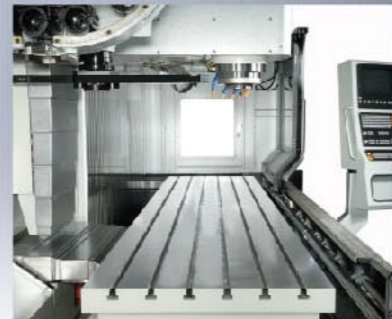

Inside the table 800mm (width)



Roller type linear rail

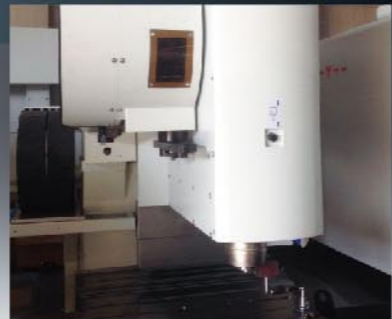

Head

# Travelling Column Machine

TCM-266/286/366/386

## FEATURES

- X axis is equipped with diameter 63 mm precision ball screw grade: C3.
- Y & Z axis are with high-speed precision and low noise ball screw dia. 40 mm grade: C3.
- X, Y & Z axis are with linear roller rail.
- TCM-266/286/366/386 provide rigidity machining to make longer bars such as aluminum, aerospace components, etc.
- TCM-266/286/366/386 allow strong fixed table (2m, 3m) to be mounted together with the base.





# Travelling Column Machine

**TCM-266/286/366/386**

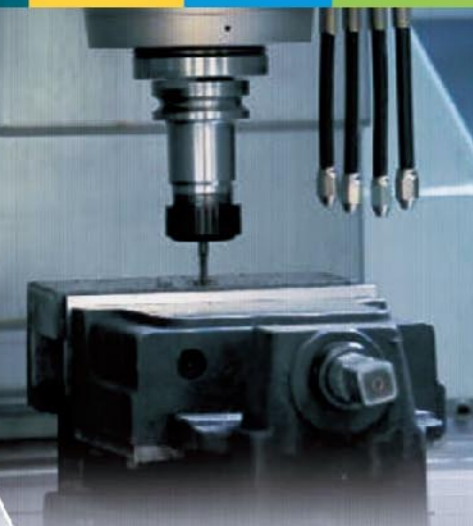

Check parallelism & height of ball screw



X axis ball screw  
• X axis ball screw assembly is with protected chip cover.



X axis with ball screw  
(TCM-266/286/366/386 & All TCM-344 model)



Coolant leak test  
• Coolant leak test for each machine before shipment.



Counterweight air cylinder  
• Head housing moves up & down by air cylinder mounted in center of housing to reduce over load when Z axis moving up .



Rigid tapping test  
• It is necessary to do rigid tap test before make shipment.  
Tapping range : 3, 4, 5, 6mm



Spindle  
• 8000 rpm spindle (standard).  
• 12000 rpm spindle (optional).

# Travelling Column Machine

**TCM-244/344/444/644**



## FEATURES

- X axis transmission by ball screw dia. 63 mm.
- Y / Z axis transmission by ball screw dia. 40 mm.
- CTS 20 bar available (OP.)
- Control system : Fancu, Mitsubishi, Siemen, Heidenhain.
- ATC installed separately on the base to reinforce the tool change.
- 24 station arm type ATC.
- Machine equipped with 2 pc auger screw.

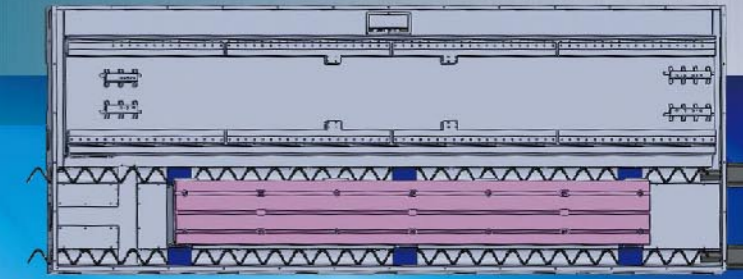

Base, Table & 2 x auger screw



ATC Place installed on the base





# Dimensions

## TCM Series

### Table T-slot & Dimension

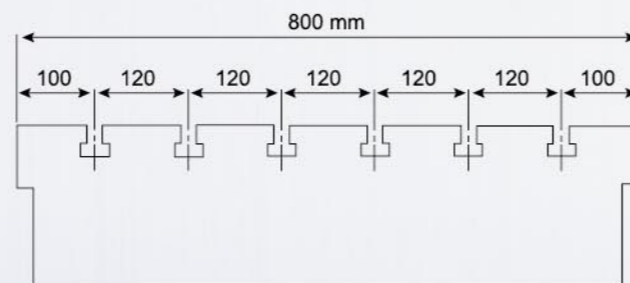
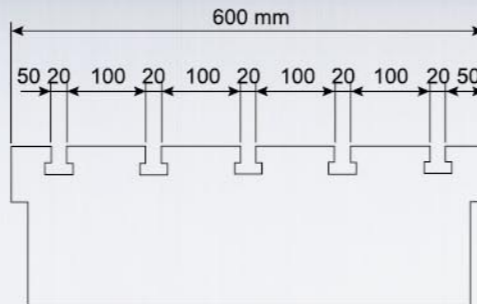
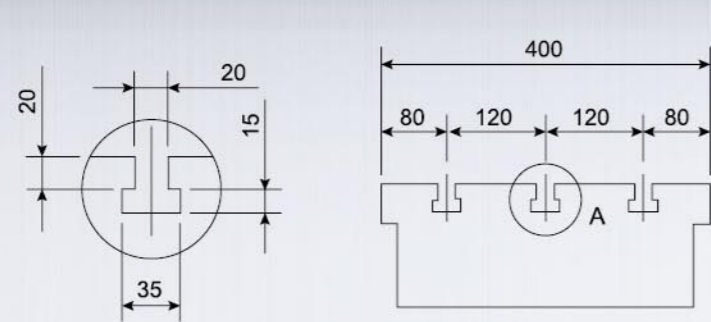

	TCM-266/286	TCM-366/386	TCM-466/486	TCM-666/686
X-axis	2000 mm	3000 mm	4000 mm	6000 mm
Y-axis	600 mm 800 mm	600 mm 800 mm	600 mm 800 mm	600 mm 800 mm
Z-axis	600 mm	600 mm	600 mm	600 mm
A	5780 mm	7320 mm	8820 mm	11300 mm
B	3316 mm 3747 mm	3316 mm 3747 mm	3316 mm 3747 mm	3316 mm 3747 mm

### Foot Print

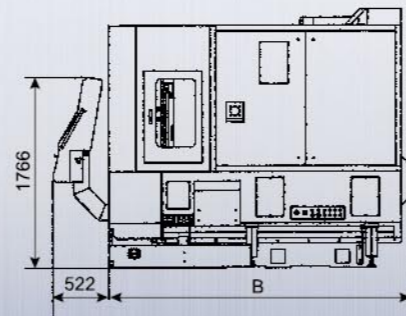
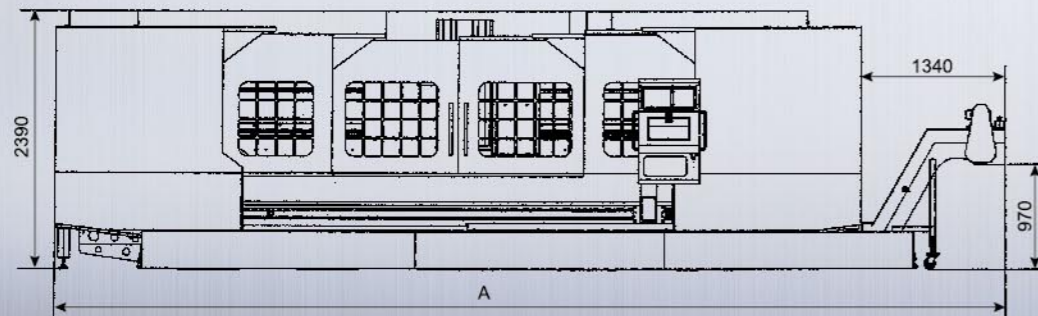

**PHANTOM**<sup>®</sup>

# Specifications & Accessories

## TCM Series

**PHANTOM**<sup>®</sup>

ITEM	MODEL	TCM-244/344/444/644	TCM-266/366/466/666/866	TCM-286/386/486/686/886
Table ( Fixed )		400 x 2000 / 3000 / 4000 / 6000 mm	600 x 2000 / 3000 / 4000 / 6000 / 8000 mm	800 x 2000 / 3000 / 4000 / 6000 / 8000 mm
Travelling column Y axis		400 mm	600 mm	800 mm
Spindle nose to top of table Min. & Max.		110 - 510 mm	110 - 710 mm	110 - 710 mm
Travelling column X axis		2000 / 3000 / 4000 / 6000 mm	2000 / 3000 / 4000 / 6000 / 8000 mm	
Z axis travel		400 mm	600 mm	
Spindle taper		BT40	BT40 ( standard ) / BT50 ( Options )	
Spindle speed		8000 rpm	60 - 8000 rpm / 60 - 6000 rpm	
Spindle motor		7.5 / 10 kW	11 / 15 kW / 18.5 / 22 kW	
X / Y / Z axis servo motor		4 kW / 4 kW / 4 kW with brake	7 kW / 4 kW / 7 kW with brake	
X / Y / Z axis rapid		12 / 12 / 12 M / min.	16 / 24 / 24 M / min.	
Cutting feed rate		1 - 6000 mm / min.	1 - 10000 mm / min.	
T slot number & pitch		See drawing P. 9	See drawing P. 9	
Tool magazine capacity ( Arm type )		24 st.	24 st. 30 op. / 20 st. 24 op.	
Max. tool diameter		150 mm	150 mm ( 24 tools ) / 80 mm ( 30 tools )	
Max. tool length		300 mm	300 mm	
Max. tool weight		7 Kgs	7 Kgs	
Position / 300 mm		± 0.01	± 0.005	
Repeatability		± 0.01	± 0.005	
Tool change time tool to tool		2.5 secs	2.5 secs	
Max. table load		1500 / 2000 / 2500 / 2800 Kgs	2000 / 3000 / 4000 / 5000 / 5500 Kgs	
Coolant capacity liter		300 / 450 / 550 / 600	470 / 550 / 660 / 830 / 980	
High floor to top of table		880 mm	970 mm	
X axis transmission		Ball screw dia. 63 mm grade C3 (TCM-244/344/444/644/266/286/366/386)		
X axis transmission (TCM-466/486/666/866/886)		Dual gear box with helical pinion & high precision helical rack hardened & grounded, backlash free		
Y / Z axis transmission		Ball screw dia. 40 mm grade C3		
X / Y / Z axis slide way		Roller type linear rail		
Roller linear rail type X / Y / Z		45 mm / 45 mm / 45 mm	55 mm / 45 mm / 45 mm	
Machine weight		12000 / 14000 / 16000 / 18000 Kgs	14000 / 16500 / 22000 / 24000 / 26000 Kgs	
Foot print L x D x H		See drawing P. 9		

### STANDARD EQUIPMENT

- 24 Station arm type (BT40)
- 20 Station arm type (BT50)
- Auto power off M30
- Coolant equipment pump & tank
- Powerful chip flash nozzle & pump
- Leveling screw and plates
- Auto lubrication system
- Spindle air blast
- Rigid tapping
- Heat exchanger for cabinet
- RS-232 interface
- Work and alarm lamp
- Fluorescent light
- Tool box with necessary tools
- Full splash guard
- Auger screw
- Interlock switch

### OPTIONAL ACCESSORIES

- Chip conveyor with bin
- 12000 rpm spindle & chiller (BT40)
- X / Y / Z axis linear scale
- Transformer (For Fanuc & Mitsubishi system)
- CTS 20 bar Simple type
- CTS 20 bar with paper filter
- 30 station arm type magazine (BT40)
- BT50 with 6000 rpm belt drive spindle
- BT50 with 8000 rpm belt drive spindle & chiller
- Tool probe
- 2 Speed gear box with chiller
- Direct drive spindle



High & low gear box



Direct drive spindle



Tool probe



Rotary Table

• 4<sup>th</sup> NC rotary table is available (optional).



CTS 20 bar simple type



CTS 20 bar with paper filter.





**PHANTOM<sup>®</sup>**

**ARCO CHEER ENTERPRISE CO., LTD.**

No. 59-10, Lane 108, Yung Feng Road, Taiping Dist., Taichung, Taiwan.  
Tel: +886-4-2277 4996      Fax: +886-4-2273 8299  
E-mail: [pcjo@ms8.hinet.net](mailto:pcjo@ms8.hinet.net)      <http://www.arcocheer.com>

• Full enclosed STEEL packing