

H Series

H22S / H22T / H32S / H32T

High Speed Bridge Type Machining Center

Box structure design, 3 axes linear guide ways,
high speed & high precision.

TAKUMI : Professional Team and Outstanding Brand

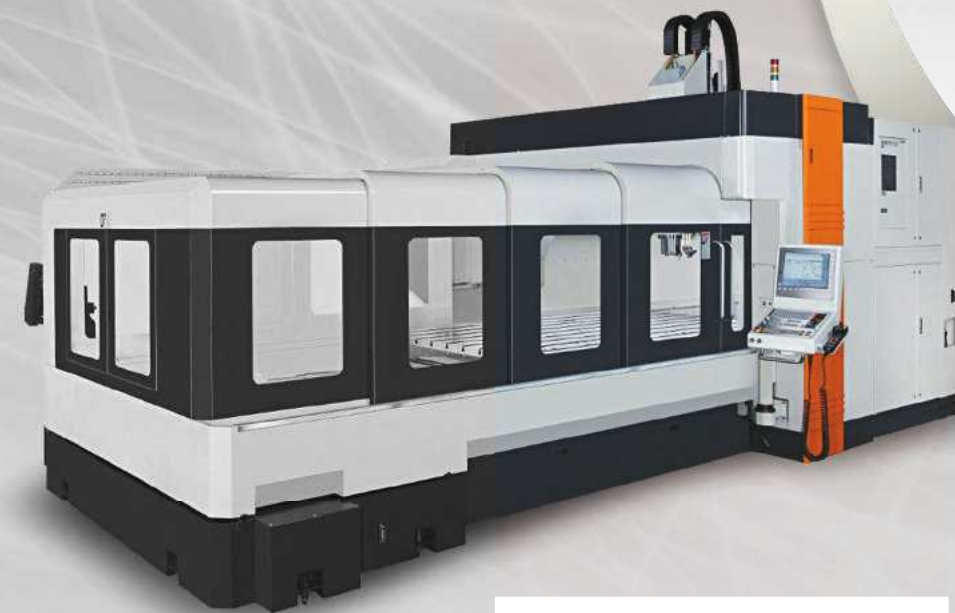

TAKUMI MACHINERY CO., LTD
No.50, 35th, Taichung Ind. Park, Taichung, Taiwan 407
Tel: +886-4-2358-3838
Fax: +886-4-2358-0176
Website : www.takumi.com.tw
E-mail : sale-os@takumi.com.tw

Agent

2014.10 DESIGNED BY TAKUMI 886-4-2296-5659



Perfect Combination of Advance Machinery Technology -- High-Speed and High-Accuracy Performance

- H-series is professionally designed for the works of metallic components and die & mold industry. 3-axis linear guide-way is of high-precision roller-type which would achieve the quickest response of acceleration and deceleration and gain the max. feed-rate at 20 m/min, together with 10,000rpm~24,000rpm high-speed spindle, broadly applied in 3C, automobile and die & mold industry.

- The extended and suspended rotary door of L-shaped, together with linear guide-way, makes it run smoothly.
- The sloping design of interior cover, together with back-flushing system and chip conveyor, makes chip removed easily with abnormal chip accumulation.
- There are no any bolts inside the cover, so chips wouldn't be accumulated.
- Windows around the machine make the operator conveniently observing the machining.
- The bigger size of door width makes the workpiece easily loaded and unloaded.
- The chip conveyor and water tank can be flexibly allocated in accordance with customer's space of factory.
- The human-friendly design of rotary operation panel makes the operator easily operate it at the different positions.

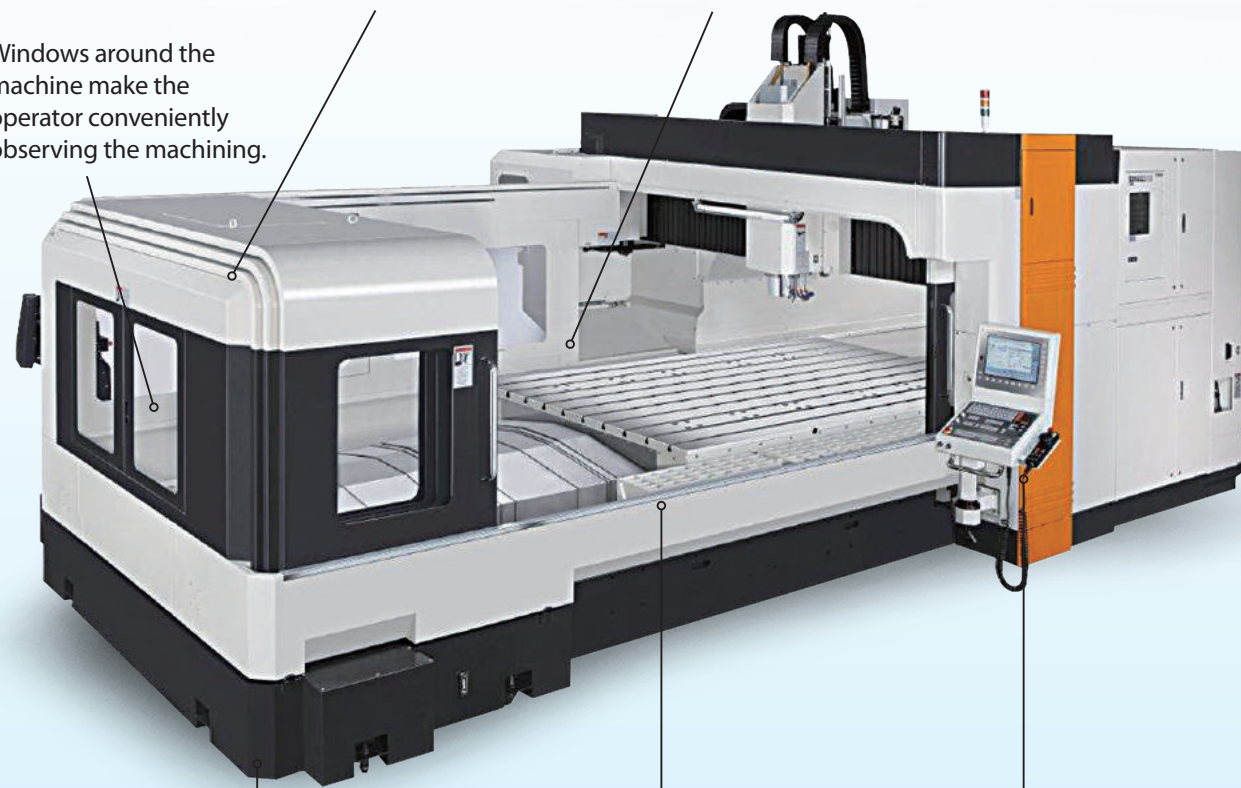

Perfect Combination of Advance Machinery Technology -- High-Speed and High-Accuracy Performance

- In X-axis movement, the ballscrew is fixed and the nut of ballscrew is driven by the servo motor so as to ensure the highest dynamic response. The ballscrew is fixed without any revolution, which decreases the flexibility of ballscrew and increases the rigidity.
- Designed as heavy-duty roller-type linear guideway.
- X-axis travel is 2,200/3,200 mm.

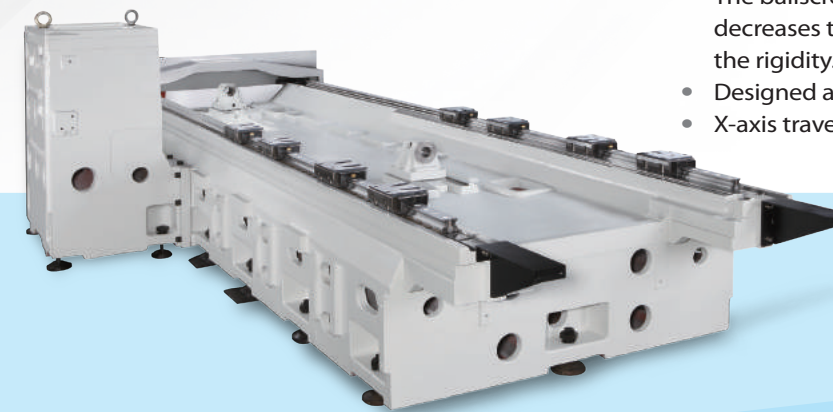

- The mechanical structures of T-shaped base and the beam & column are of one-piece integrated casting iron, which assure the optimum rigidity and stability.
- The mechanical structure of Y-axis is designed as ladder-shaped big-width, which makes its structure much more stable.
- Y-axis travel is 1,600/2,200 mm.

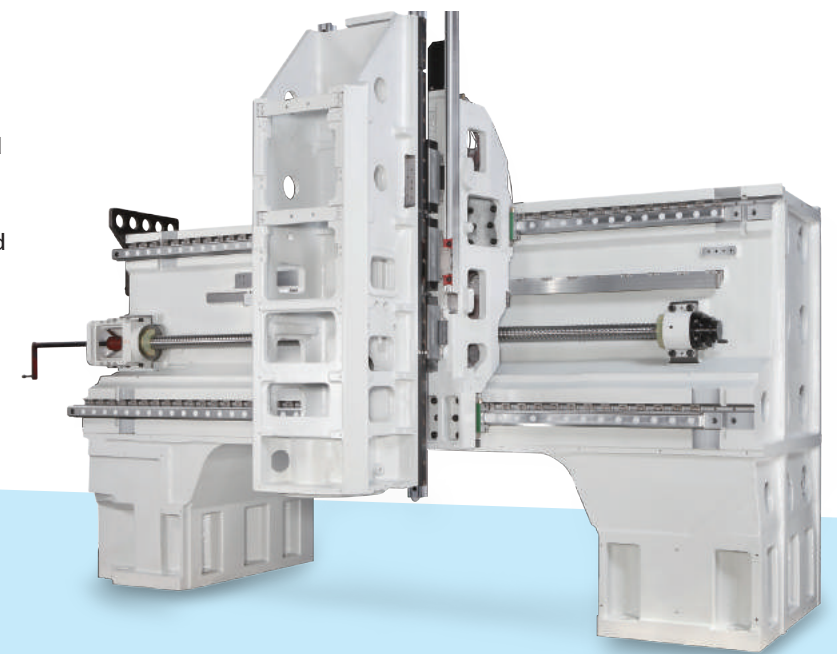

Mechanical Structure specially designed for High-Rigidity and High-Precision

- 3 axes travel : X=2200~3200mm, Y=1600~2200mm, Z=800mm
- 3 axes are equipped with roller type linear guide ways to optimize acceleration/deceleration.
- Non-counter balance on spindle head allows high speed and quick response.
- Bed, columns, saddle and other main castings are made of Meehanite grade cast iron and released the stress by heat treatment, ensuring the best structural stability and positioning accuracy.
- The ladder type design of linear guide ways on the beam provides wider supporting surface for saddle, ensuring powerful and stable cutting performance.
- 3 axes ball screws pretension design reduces the thermal deformation, offering the best accuracy.
- 3 axes ball screws and linear guide ways are lubricated by centralized automatic lubrication system (oil type).
- Absolute encoder motors are used in 3 axes feeding system to ensure the positioning accuracy.
- The device of oil & coolant separation on machine bed and oil skimmer on coolant tank prolongs the service life of coolant.
- Fully enclosed splash guard provides safety and clean operating environment.

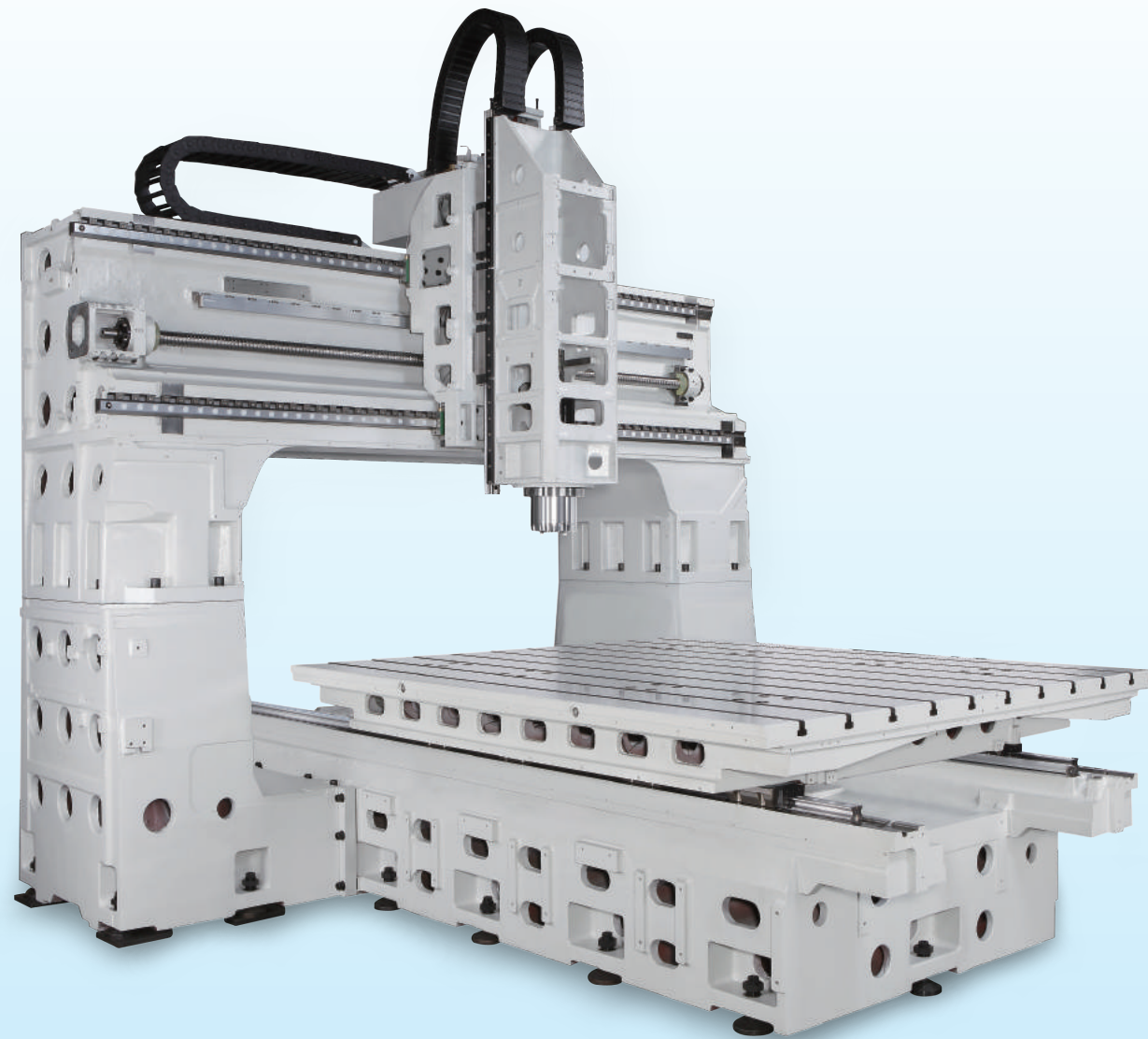

Mechanical Structure specially designed for High-Rigidity and High-Precision



- 6-piece-of-slide at Z-axis linear guide-way on H22/H32 keeps the high accuracy after long-term operation and makes sure its long service hours.
- The design of the optimal topology optimizes the structural rigidity of the casting iron.
- Z-axis travel is 800 mm.

- No. of slide at 3-axis linear guide-way on H22~H32

Axis	Model	H22S	H22T	H32S	H32T
X axis		8	8	12	12
Y axis		4	4	4	4
Z axis		6	6	6	6

- 3-axis linear guide-way is of roller-type, made in Japan.

- The chip augurs, allocated on both sides of the base, make chips removed efficiently and quickly.
- The streamline design of interior cover/ splash guard makes chips removed/ cleaned easily.

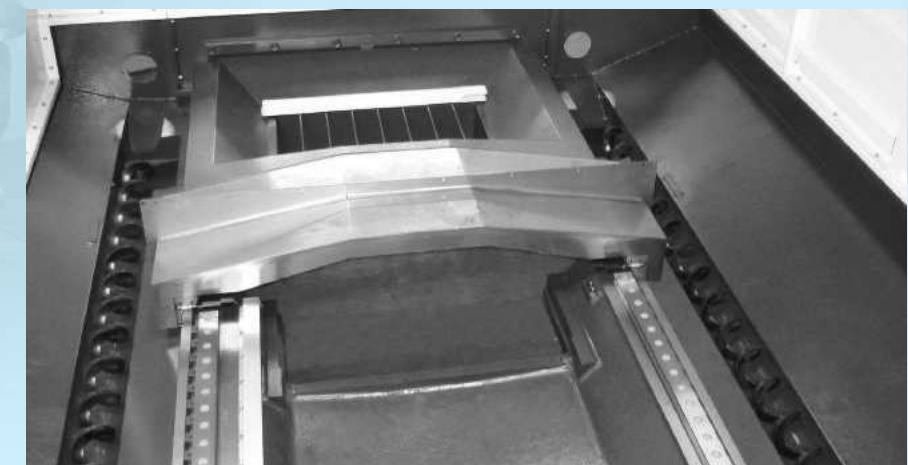

High Accuracy and High Performance Spindle

- H series provides direct-drive type spindle and built-in type spindle to meet different machining requirements. The spindle speed range is 10,000rpm~24,000rpm.
- Spindles are from professional spindle manufacturers, featuring high accuracy and high performance.
- The built-in thermal compensation system (optional: IBAG spindle only) decreases the effect of thermal deformation, assuring the accuracy during operation.
- Spindle cooling system reduces thermal deformation and prolongs working life of spindle.



Spindle Power & Torque Chart

- Direct-drive type spindle, 15/18.5 kW, 15000rpm (standard, for FANUC NC only)

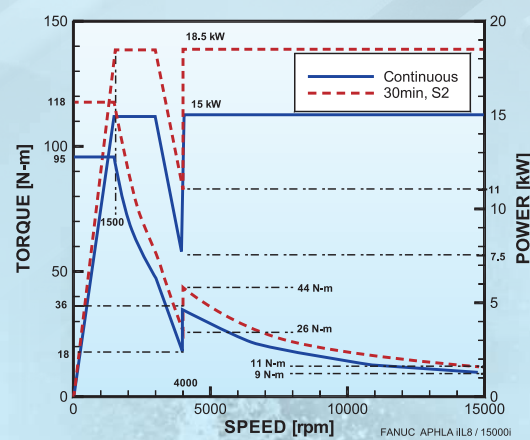

- Direct-drive type spindle, 22/26 kW, 10000rpm (optional, for FANUC NC only)

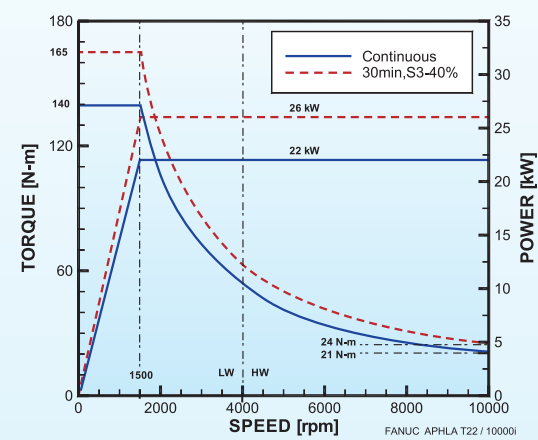

- Direct-drive type spindle, 22/30 kW, 10000rpm (optional, for HEIDENHAIN NC only)

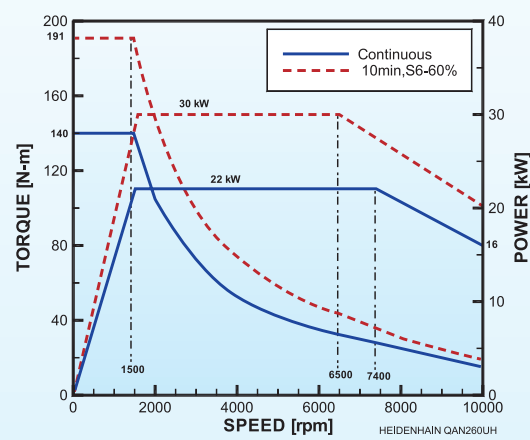

- Built-in type spindle (IBAG), 25/33 kW, 24000rpm (optional)

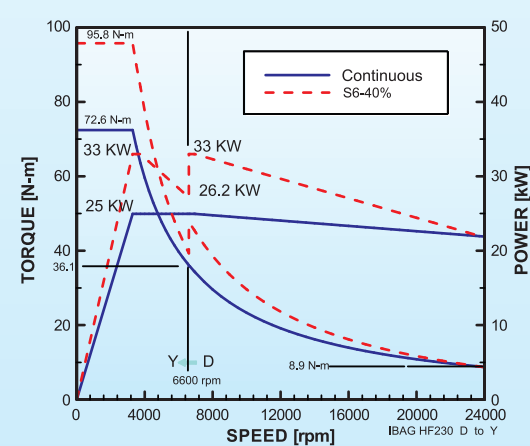
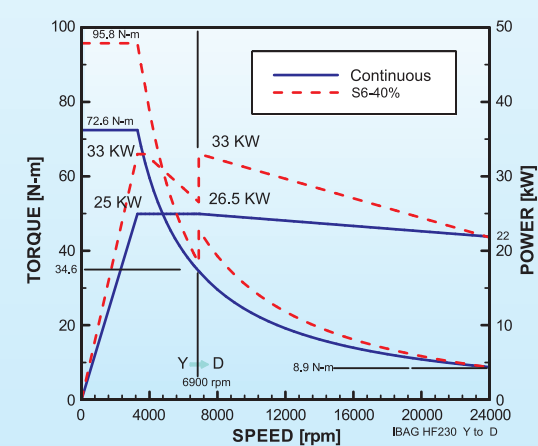

ATC

- Armless type ATC (standard)

- 20T, BBT40



- Arm type ATC (optional)

- 30/48/60T, BBT40
- 32/60T, BBT50



Optional Accessories



- Oil mist collector



- Linear scales (3 axes)



- Workpiece measurement system



- Tool length measurement system



- Ball screw cooling system

ISO9001:2008 Quality Management



• Scrapping calibrated by the test bar
All of the main assembling surfaces are hand scraped to optimize machine accuracy.



• Ball bar test



• Laser inspection



• Spindle test



• Temperature control room



• Parts inspection before installation

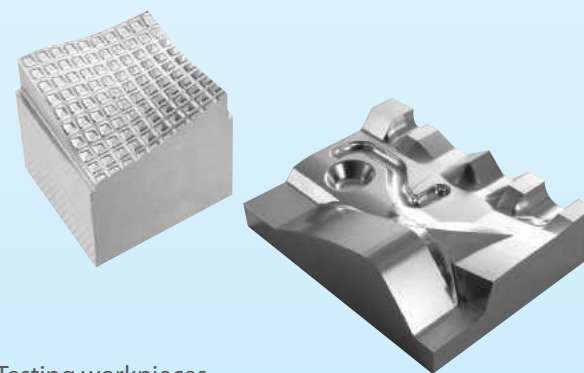

• Testing workpieces

H22S Dimensions

Table & T-slot

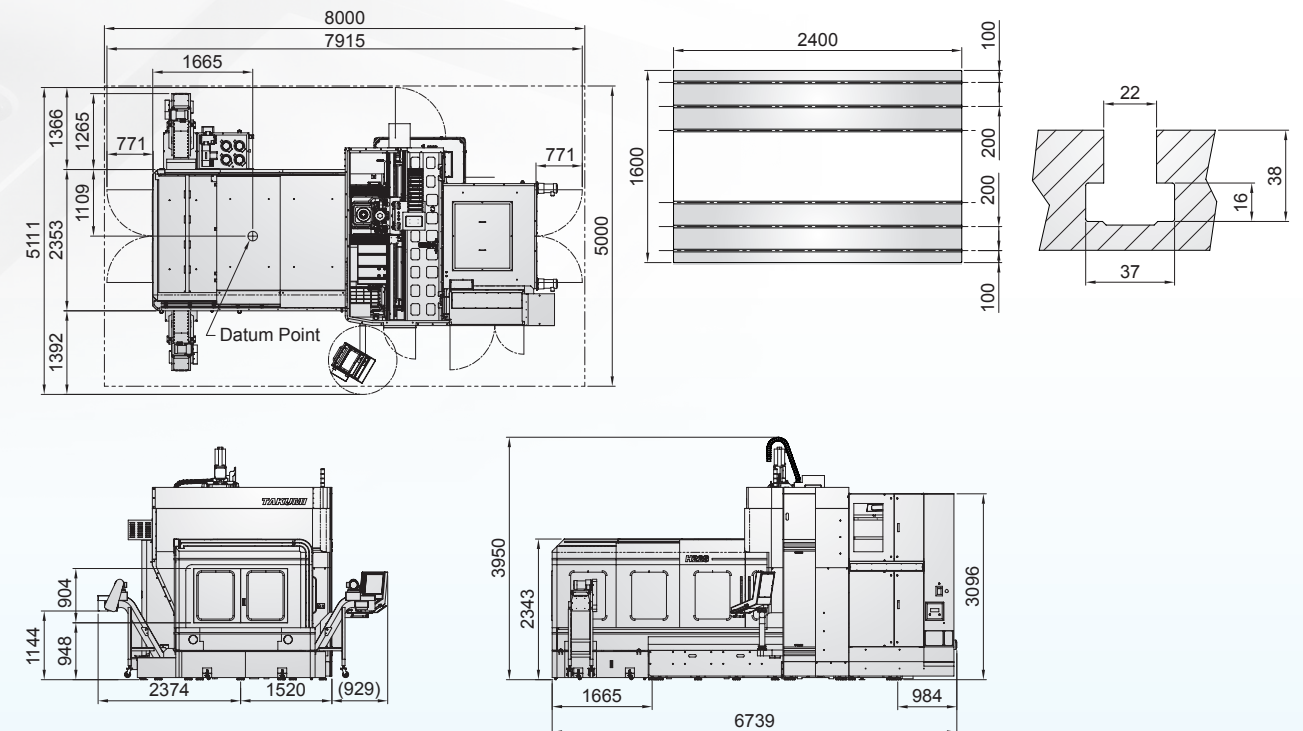

H22T Dimensions

Table & T-slot

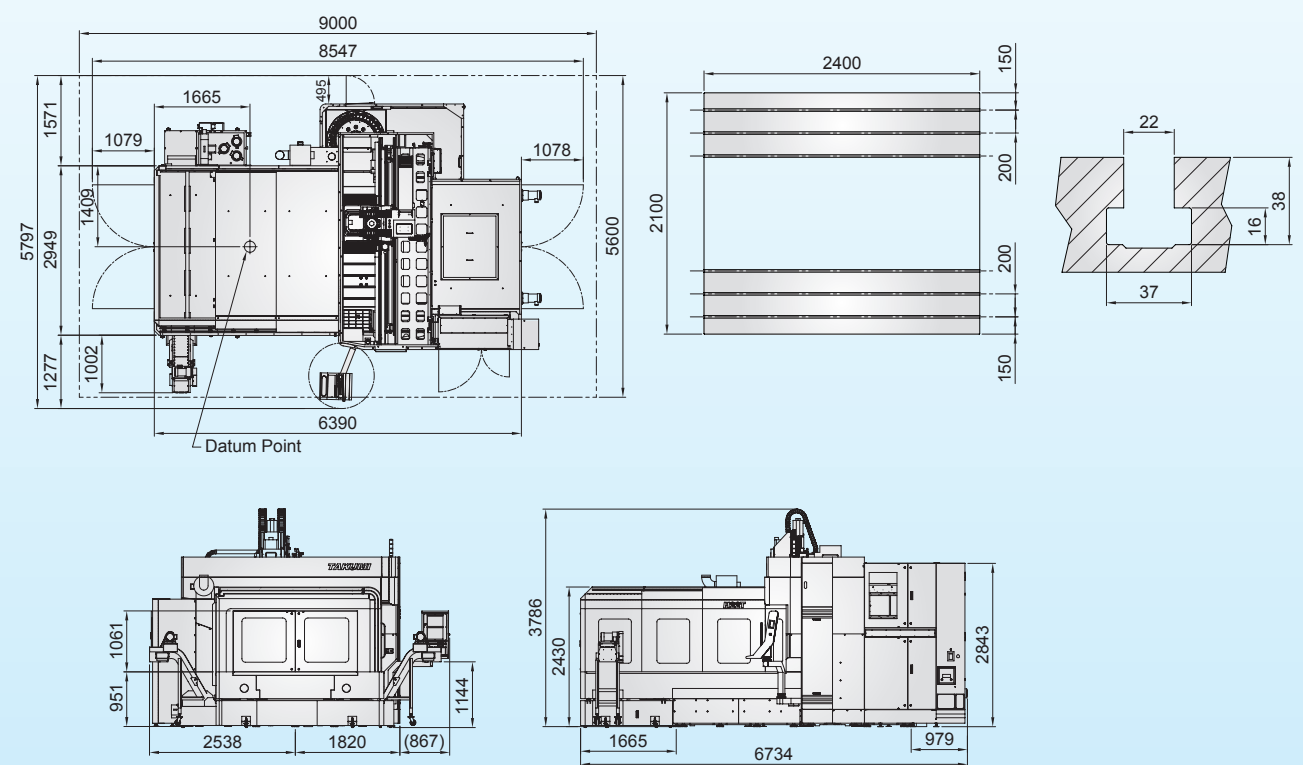

Unit : mm

H32S Dimensions

Table & T-slot

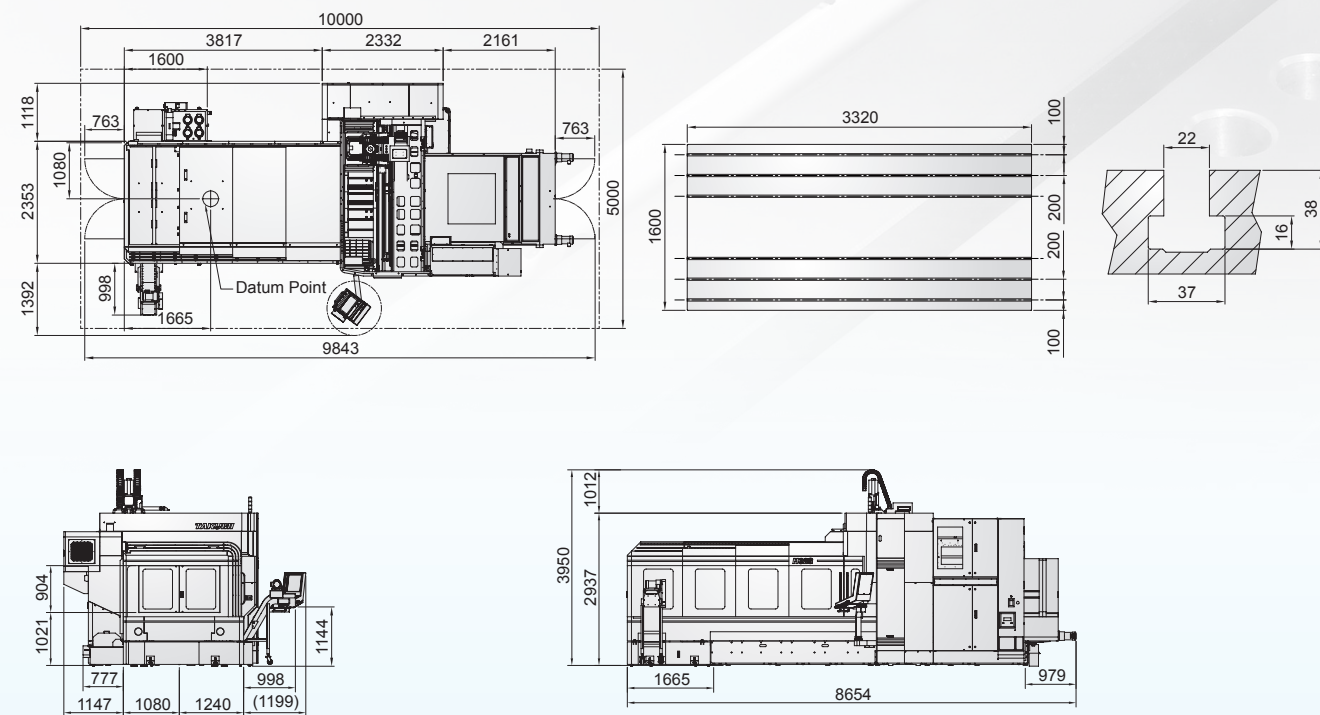

H32T Dimensions

Table & T-slot

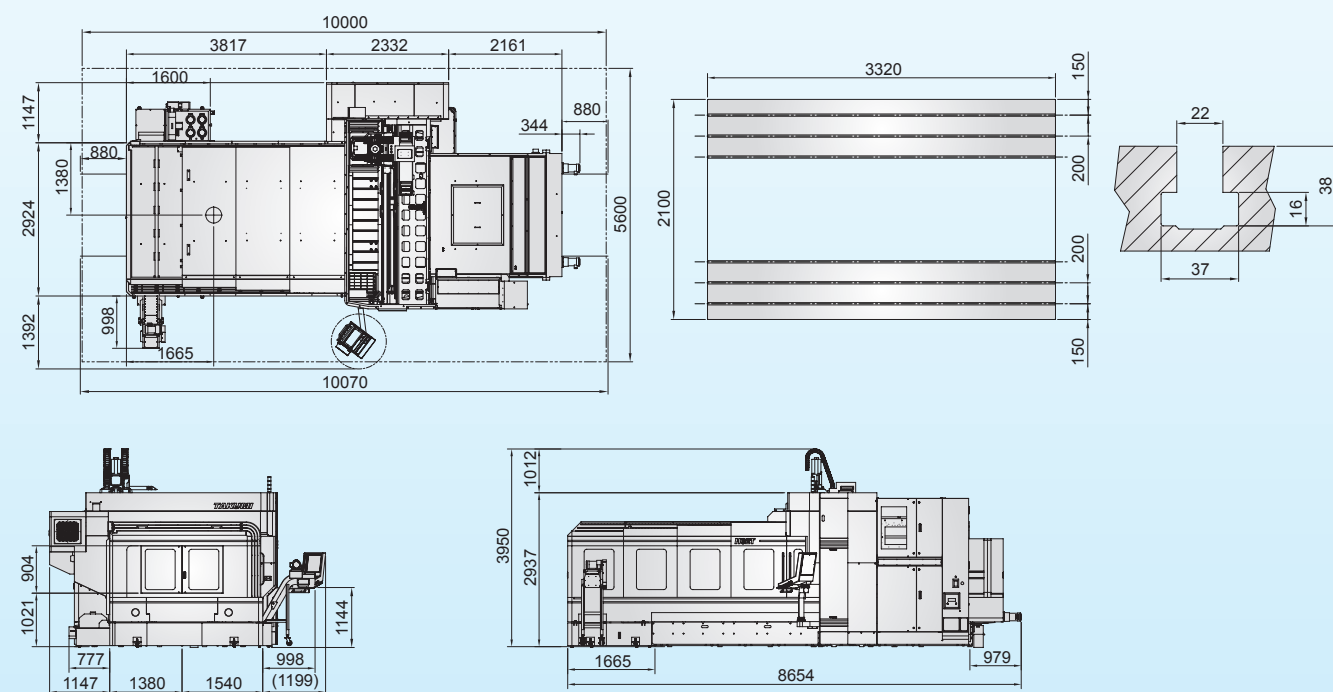

Unit : mm

Specifications

Travel	Unit	H22S	H22T	H32S	H32T
X axis	mm	2200	2200	3200	3200
Y axis	mm	1600	2200	1600	2200
Z axis	mm	800			
Distance from spindle nose to table	mm	150-950			
Distance between columns	mm	1750	2350	1750	2350
Table					
Dimension	mm	2400x1600	2400x2100	3320x1600	3320x2100
Max. load	kg	8000	8000	8500	8500
T-slot (width X pitch X number)	mm	22x 200 x8	22x 200 x10	22x 200 x8	22x 200 x10
Spindle					
Spindle type	—	Direct-drive			
Spindle speed	rpm	15000			
Spindle motor power (cont./30 min rated)	kW	15/18.5			
Spindle taper	—	BBT40			
Feed rate					
Rapid traverse (X/Y/Z)	m/min	20/20/20	20/16/20	16/20/20	16/16/20
Cutting feed rate	mm/min	1~12000	1~12000	1~12000	1~12000
Motor power (X/Y/Z)	kW	14/9.0/5.5			
ATC & Magazine					
ATC type	—	Armless			
Magazine capacity	pcs	20			
Max. tool diameter (next pockets empty)	mm	105/150			
Max. tool length	mm	300			
Max. tool weight	kg	7			
Tool shank	—	BBT40			
Pull stud	—	MAS 1			
Space & System Requirement					
Pneumatic pressure	kgf/cm ²	6			
Electrical power consumption	kVA	90			
Machine net weight	kg	27000	31000	33000	37000
Max. floor space (W X L X H)	mm	4823 X 6739 X 3950	5225 X 6739 X 3950	4666 X 8654 X 3950	5266 X 8654 X 3950

■ Standard Accessories

- FANUC 31i MB controller
- 15000 rpm, BBT40, direct-drive type spindle
- 20T, BBT40, armless type ATC
- Spindle air blast
- Cutting air blast
- Spindle cooler
- Cutting coolant system
- Centralized automatic lubrication system (oil)
- 3 axes absolute encoder motors
- Fully enclosed splash guard
- Working lamp
- Indication lamp
- Washing gun & air gun
- Oil skimmer
- Coolant tank & coolant flushing system
- Steel belt type chip conveyor
- Manual pulse generator
- Ethernet & RS-232C interface
- Air conditioner for electrical cabinet
- Tool kits
- Anchor bolts, leveling blocks and bolts
- Operation manuals, PLC, electrical circuit diagrams
- One-year machine warranty (Spindle warranty depends upon spindle manufacturer)
- Controller warranty (FANUC : 24 months from shipping date)

■ Optional Accessories

- HEIDENHAIN iTNC 530 controller
- 10000rpm, BBT50, direct-drive type spindle
- 24000rpm, HSK A63, built-in type spindle (IBAG)
- 30/48/60T, BBT40, arm type ATC
- 32/60T, BBT50, arm type ATC
- Coolant through spindle (20BAR - 70BAR)
- Spindle thermal compensation system (For IBAG spindle only)
- Ball screw cooling system
- Oil mist device
- Oil mist collector
- Linear scales (3 axes)
- Workpiece measurement system
- Tool length measurement system
- Rotary table (The 4th/5th axis)
- Scraper type chip conveyor
- Transformer
- CE (CE area only)

■ BBT40 Tool Shank & Pull Stud

