



<http://www.kaoming.com>

BRIDGE

PRESENT AND FUTURE



KAO MING MACHINERY INDUSTRIAL CO., LTD.

Head Office

No.861, Sanfong Rd., Fongyuan City, Taichung County, 42073 Taiwan.

CTSP

No.53, Houke S. Rd., Houli Township, Taichung County, 42152 Taiwan.

TEL: +886-4-25577650 FAX: +886-4-25577630

E-MAIL: km@kaoming.com.tw



KMC-SV/SV-H Series

KMC-SD Series

KAO MING MACHINERY INDUSTRIAL CO., LTD.

THE HIGH-TECH of KAO MING

THE POWER of TOMORROW

"I have a dream that one day the rough places will be made plain, and the crooked places will be made straight," Martin Luther King, Jr. said. Foresighted industrial innovation is always based on the constructive thinking of "dare to dream."

Kao-Ming Machinery Industrial Co., LTD perseveres in its attempt with innovative and revolutionary ideas to develop advanced technology and professional products in the related industrial field. Nowadays, it is the very moment for the advanced industry to improve human beings' lives through all who dare to dream. Let's take the opportunity to succeed with Kao-Ming!

Yesterday's Honor. Today Leaps!



01

02

KMC-SV / SD Series

HEAVY-DUTY CUTTING

SV SD FEATURES

- SV-series is designed from the SD-series with 33.5"(850mm)Z-axis travel to accommodate taller parts.
- The X, Y & Z axis are fully support by rigid box ways.
- The "and" models with the longer distances between the columns, utilize a total of 4 box ways on the X-axis for enhanced rigidity. The table never travels overhang hereby ensuring the rigidity throughout the entire travel of all axes.
- The Y axis utilizes a superior design where by the lower slideway is offset a full 2.76"(70mm)forward from the upper slideway. This greatly enhances the rigidity of the headstock by bringing the center of gravity back into the upper support.
- Only a distance of 3.35"(85mm) from spindle center to Z-axis slideway
- Two gear ranges, helical and spur gears support the spindle transmission system for machining large cavities at low RPM.



(with various options)

KMC-2000SV / 3000SV / 4000SV / 5000SV / 6000SV / 8000SV

KMC-SV/SV-H/SD Series

03



RIGID POWERFUL SPINDLE HEAD

TWO GUIDEWAY BASE

SV SD HIGHLY RIGID, DOUBLE BOX WAY CONSTRUCTION

The heavy duty, box way construction is of Meehanite cast iron and is designed and inspected by FEA(Finite Element Analysis) to ensure excellent rigidity, suitable for both high speed and heavy duty cutting for many years.

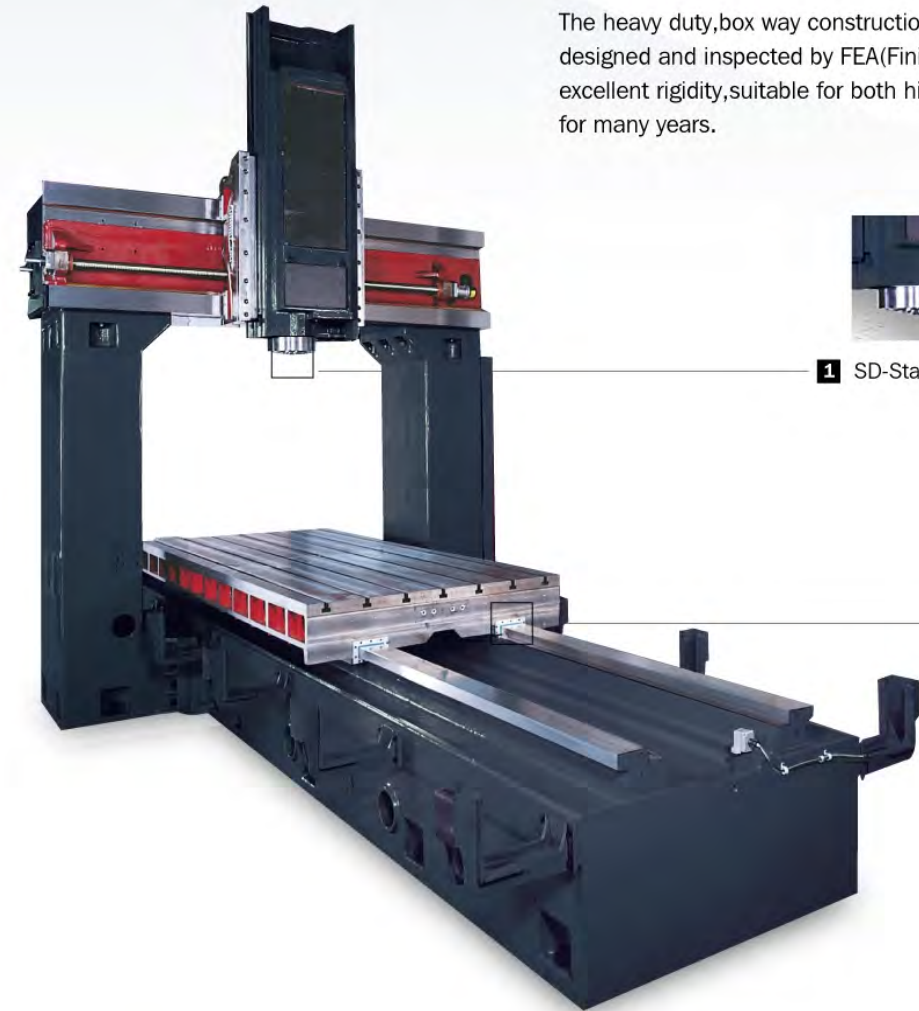

1 SD-Standard spindle head

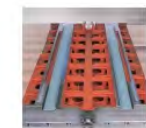

2 Precision scraping

SV SD FOUR GUIDEWAY HIGH RIGIDITY STRUCTURE

For big parts machining will need heavy loading capacity, so our "D" model up (distance between two columns 90.55"(2300mm)), machine base has four box way to support - a slide and rolling combined design, center box way for main support is hardened and ground, with Turcite-B which have strong absorb ability can keep dynamic rigidity during heavy cutting, and 2 sides box way the same as center only have extra roller-type recirculating bearing to strengthen support. This design can less loading during movement and get more tolerance. And table's 2 end-front and rear of sliding surface also have roller-type recirculating bearing for precisely adjust the geometry accuracy to use. To assembly with recirculating bearing, hardness of box way surface must be more than HRC58°, Therefore we make box way tightened on the casting base or welded on the fabricated base.

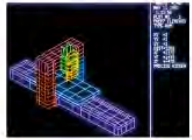

The double column and closed style construction, with all three axes fully supported, minimizes the displacement brought on by the load of the work piece and heavy cutting forces. The displacement from heavy cutting, of course, is a common problem with the overhang of the normal "C" frame type machining center, with an open style construction.

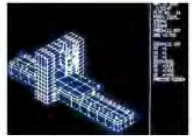

The superior, hardened, ground double guide way constructed bed is designed for a distance between columns of under 82". A total of four box ways are utilized for the models with a distance between columns of over 82". All surfaces that make contact with the slideways are lined with Turcite B to ensure long lasting, and optimum rigidity during heavy cutting conditions. Precision scraping of the Turcite B surface ensures smooth axis traverse without stick-slip movements, to further enhance the machine's overall rigidity and reliability.

FOUR GUIDEWAY BASE

SV SD COLUMN AND CROSSBEAM

Two column and crossbeam is of Meehanite cast iron, after annealing to have internal stress relief can provide spindle head's more stronger support and to maintain Z axis with both X and Y axes perpendicular geometry accuracy.

SV SD TABLE

Cast iron table with density rib is the best structure to against bending and twist stress, not easy to deformed. And can make sure 3 axes measuring tolerance with this datum plane.

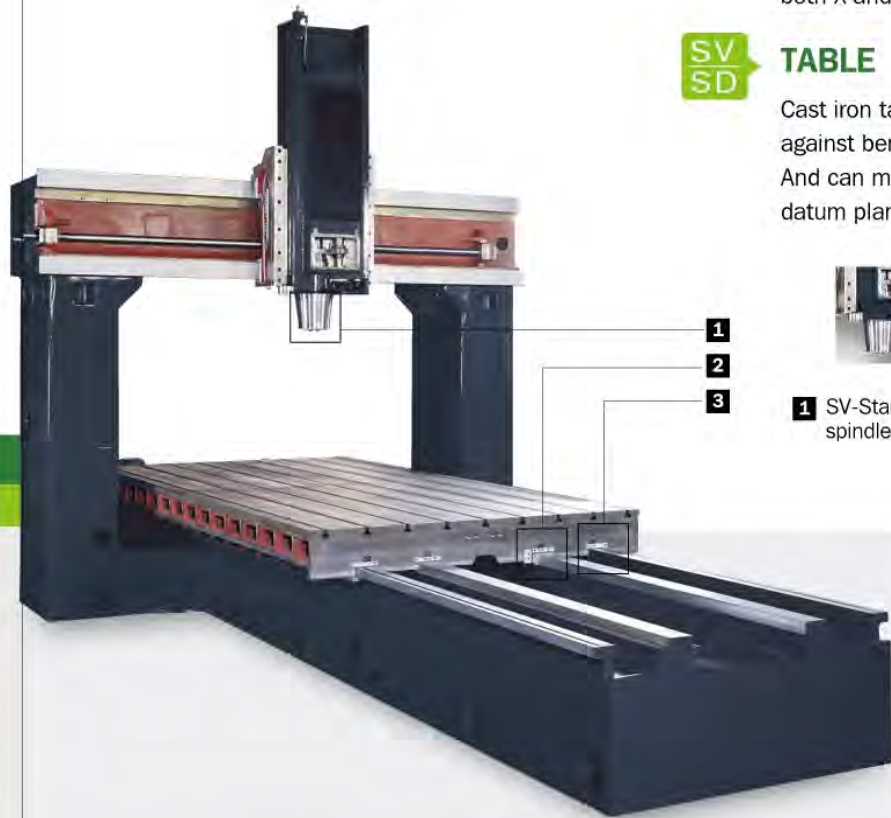

1
2
3



1 SV-Standard spindle head



2 Precision scraping



3 Roller-type recirculating bearing

HIGH RIGIDITY STRUCTURE HIGH POSITIONING ACCURACY

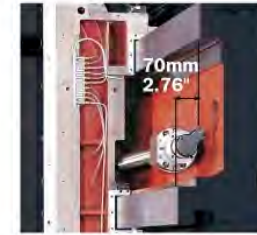

Y-AXIS STEP DESIGN

The Y-axis utilizes a superior design whereby the lower slideway is offset a full 2.76" [70mm] from the upper slideway. This greatly enhances the rigidity of the head-stock by bringing the center of gravity back into the upper support which rests atop the massive columns. This design provides an extremely stable foundation for the spindle head to travel on further enhancing the machine's performance when doing heavy cutting.



MINIMAL DISTANCE FROM SPINDLE CENTER LINE TO Z-AXIS SLIDEWAY

This distance is only 3.3", which is the smallest in the industry. This efficient design provides a much more stable headstock by minimizing the amount of cantilever from the slideways. This design also greatly decreases the amount of heat displacement that can be associated with the rise of spindle temperature, which further increases the machine accuracy.



INNER COOLED BALLSCREW

A properly preloaded and pretension, large diameter ballscrew with a double re-circulating ball nut is used for each axis throughout the entire machine series. For the machine models KMC-3000~KMC-6000 with the longer X-axis travels, a hollow state-of-the-art ballscrew is used. Cooled oil continuously flows through the center of the ballscrew.

The temperature of all the oil is cooled, circulating through an external heat exchanger. This greatly enhances the machine's performance and accuracy by practically eliminating thermal growth of the axis especially when using the full traverse.

Both support ends of the X-axis ballscrew are equipped with a special design to cool the bearings by air. This superior design is unique to Kao Ming.



BALLSCREW SUPPORT MECHANISM

For the machine models KMC-5000~KMC-8000 with the longer X-axis travels, there is a special mechanism (Std.) to balance the gravity weight of the ballscrew and to get better performance of the system.

INTEGRAL BALLSCREW MOUNTING BRACKETS

The ballscrew are supported by a double anchor system, which greatly improves the rigidity of the axis by minimizing vibration during feeding. The mounting brackets for the Y and Z-axis ballscrews are integrated with the saddle and crossbeam castings to maximize the rigidity further.



EXTERNAL AXIS POSITION FEEDBACK

All 3 axes utilize an external feedback pulse coder for positioning. For machine models 2000SV/SD-A, B&C, the x-axis position feedback system is directly driven, with the servo motor coupled directly to the ballscrew. For machine models over 3000SV/SD, the ballscrew is driven by a motor and gear box with a gear ratio of 1:2 for added strength to the axis feed system. The external position feedback pulse coder is coupled directly to the opposite end of the ballscrew. This allows for high positioning accuracy to be maintained by measuring the true rotation of the ballscrew.



AXIS SAFETY PROTECTION

Safety couplings are used where the drive motors adapt to the ballscrew. These devices greatly minimize damage that may occur during a collision or overload condition.



- Extended spindle (SD-Series optional) is standard accessories(SV-Series)that applies to deep hole drilling and concave milling.
- Specially designed tool unclamp cylinder.The spindle utilizes a "state of the art" designed hydraulic cylinder.This special design totally eliminates any outside forces from being applied to the spindle bearings when releasing the tool.

- Pretensioned ballscrews with air cooled thrust bearing.
- Oil cooled X-axis ballscrew(Model3000-6000).
- Dual arm ATC system.
- Coolant through spindle system (option) can clean chips from high speed cutting and restrain heat.
- With optional Fanuc Data Server,64-bit RISC processor and NURBS Interpolation to achieve Hi-Speed and Hi-Accuracy Die / Mold Machining.



(with various options)

KMC-2000SD / 3000SD / 4000SD / 5000SD / 6000SD / 8000SD



SV SD SPINDLE OUTPUT AND TORQUE (FANUC SPINDLE MOTOR)

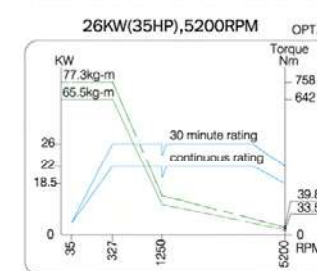
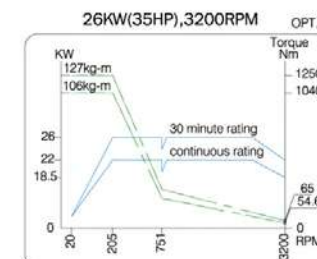
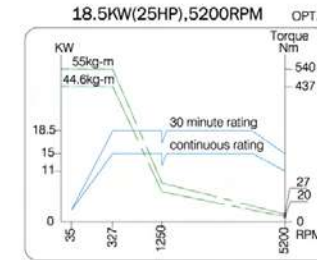
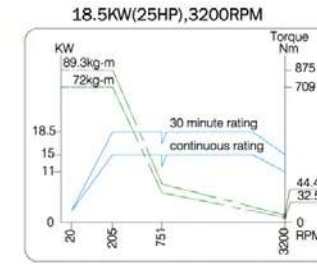

RIGID & VERSATILE SPINDLE HEAD

- The spindle transmission incorporates both helical and spur gears for driving the spindle.Because of the increased contact surface of each mating gear,a much more stable,stronger,and smoother rotation is provided.
- Even at speeds as low as 6 rpm.The machine can easily perform boring of large diameter holes.
- The entire spindle and transmission units are cooled by a constant circulation of oil.The oil re-circulates through a refrigeration unit,equipped with a thermostat.With this unit,the spindle is able to maintain a constant temperature in relation to the ambient temperature. This greatly reduces the thermal growth of the headstock, for accurate positioning and greatly increases the life span of the spindle and transmission.
- The optional,Coolant Through the Spindle feature utilizes a complete pump/filtration system,rather than a single auxiliary pump as commonly used by our competition.This system is equipped with a large 600L capacity reservoir,high pressure pump,and two precision filters,with a choice of various output pressures.
- The entire headstock assembly is counter balanced by a single hydraulic cylinder. This ensures a consistent smooth and even movement of the Z-axis without overloading the servo drive motor.

SV SD MAIN FEATURES

- The superior box-shaped spindle head design allows for 2 choices of spindle configurations,for a wide range of multiple machining.
- The "SD" series is standardly equipped with a flush mounted spindle for enhanced rigidity,and can be ordered with the optional Angle.Head or Universal head attachments.The "SV" series is standardly equipped with an extended spindle design,and is optional on the "SD" series,if concave or deep pocket machining is your application.
- The "SD" series spindle diameter is $\phi 3.54"$ (90mm) and supported by a total 4 precision class(P4),angular contact bearings The "SV" series spindle diameter is $\phi 3.94"$ (100mm) and is supported by a total of 5 precision class (P4), angular contact bearings. Both designs are enclosed and grease lubricated for many years of optimum performance.

COOLANT THROUGH SPINDLE SYSTEM

	Medium Pressure	High Pressure
Pressure	20 bar(284psi)	45 bar(639psi)
Quantity	30 L/min[7.92gal/min]	30 L/min[7.92gal/min]



The spindle also utilizes a "state-of-the-art" designed hydraulic cylinder.This special design allows the cylinder to slightly float thereby eliminating any outside forces from being applied to the spindle bearings when changing tools.

HEAVY DUTY CUTTING



POWERFUL, HIGH SPEED ATC

The standard tool magazine is equipped with 30 tool capacity, and can be upgraded to a 40, 50, 60, or 90 tool capacity. The unique double-arm tool change design, powered by a durable, high speed motor, greatly reduces tool change time to less than 6 sec. (T to T). The tool change storage and retrieval system is accomplished by a high quality, high performance, bi-directional hydraulic index motor which further enhances the ATC.



AUTOMATIC TOOL MAGAZINE DOOR

The tooling within the magazine is well protected from chips, coolant, and other debris by a fully programmable door. The door operates in conjunction with the ATC, eliminating the need to program it separately.

HIGH EFFICIENCY ATC



CONVENIENT TOOL LOADING SYSTEM

Tool loading and unloading can be performed at either the spindle or tool storage magazine. A foot pedal is provided at both locations allowing for easy handling of even larger tools.

OUTSTANDING CUTTING CAPACITY

1099 c.c./min. [67cu.in/min]		30HP/35HP
FACE MILLING		
Tool	ø125 mm	 
Cutting Width	90 mm	
Spindle Speed	650 rpm	
Material	S45C	
Feedrate	2444 mm/min	
Depth	5 mm	
Cutting Capacity	1099 c.c./min	



Optionally Available



Angle Head



Universal Head

CUTTING CAPACITY EXAMPLE

		Tool	Workpiece Material	Spindle Speed	Cutting Width	Cutting Depth	Feedrate	Cutting Capacity
Angle Head	Face Milling	ø125 mm [5"]	S45C (1045)	500 rpm	90 mm [3.54"]	5 mm	825 mm/min [32.4ipm]	371 cc/min [22.6cu.in/min]
Universal Head				350 rpm	80 mm [3.15"]	[0.2"]	1200 mm/min [47.2ipm]	480 cc/min [29.2cu.in/min]
Angle Head	Drilling	ø55 mm [2"]		150 rpm	-	-	40 mm/min [32.4ipm]	-
Universal Head				120 rpm	-	-	42 mm/min [1.65ipm]	-

INSPECTION & ACCURACY

INSPECTION EXAMPLE



- 1 Thermal Compensation Test
- 2 Straightness Measurement
- 3 Geometric Accuracy Inspection
- 4 Kinematic Measurement
- 5 Rigidity Test
- 6 Lighting Measurement
- 7 Laser Positioning Accuracy Inspection



MACHINE STANDARD AND OPTIONAL ACCESSORIES



Automatic Touch Probe Centering System



NC Rotary Table



Automatic Tool Length Measuring System



Oil Cooling System

STANDARD ACCESSORIES

1. Coolant Equipment
2. Centralized Automatic Lubrication System
3. Rigid Tapping
4. Splash Guard
5. Adjusting Tools And Box(1 Set)
6. Manual And Electrical Drawing(1 Set)
7. Leveling And Foundation Fittings
8. Work Light
9. Spindle Cooling System(Chiller Unit)
10. Alarm Lamp
11. Air Blast
12. Automatic Power Off
13. Operation Finish Lamp
14. Screw-type Chip Conveyor
15. Transformer(Except 220v)
16. Inner Cooled Ballscrew
17. Slideway Covers
18. Magazine Safety Guard
19. Electrical Cabinet Light
20. Manual Tool Change and Foot Switch
21. Reinforced Foot-Stand at Both Table-End
22. Electrical Cabinet Cooling System (Air Conditioner)

OPTIONAL ACCESSORIES

1. Link-type Chip Conveyor
2. Mist Coolant Unit
3. NC Rotary Table
4. Angle Head(Manual)
5. Universal Head(Manual)
6. Oil Hole Drills Interface
7. Linear Scale Feedback System
8. Automatic Tool Length Measuring System
9. Automatic Touch Probe Centering System
10. Tracing/digitizing System
11. Coolant Through Spindle System(A,B Type)
12. CAT50, DIN50, ISO50 Tool Shank
13. KMTCS-Kao Ming Thermal Compensation System
14. Larger Capacity Coolant Tank
15. Anchoring Alignment System
16. Fully Enclosed Splash Guard
17. Coolant Purifying System
18. Coolant Cooling System
19. Hydraulic Cooling System
20. Paper(Belt)filter System
21. CRT Cooling System(Air Conditioner)
22. Oil Skimmer System
23. Electrical Cabinet Cooling System(Up to 45°C Capacity)
24. Specified Sub Table, T-slot, Machine Color
25. Extra Load Capacity

Link-type Chip Conveyor (Optional)



DOUBLE-COLUMN MACHINING CENTER

SPECIFICATIONS

Unit: mm (inch)

ITEM	KMC-2000SV/SD						KMC-3000SV/SD						KMC-4000SV/SD						KMC-5000SV/SD						KMC-6000SV/SD						KMC-8000SV/SD																																		
	A	B	C	D	E	F	1500	1800	2100	2300	2500	2800	1500	1800	2100	2300	2500	2800	1500	1800	2100	2300	2500	2800	1500	1800	2100	2300	2500	2800	1500	1800	2100	2300	2500	2800	1500	1800	2100	2300	2500	2800																							
Distance Between Two Columns							1500 (59.05)	1800 (70.86)	2100 (82.6)	2300 (90.55)	2500 (98.43)	2800 (110.2)	1500 (59.05)	1800 (70.86)	2100 (82.6)	2300 (90.55)	2500 (98.43)	2800 (110.2)	1500 (59.05)	1800 (70.86)	2100 (82.6)	2300 (90.55)	2500 (98.43)	2800 (110.2)	1500 (59.05)	1800 (70.86)	2100 (82.6)	2300 (90.55)	2500 (98.43)	2800 (110.2)	1500 (59.05)	1800 (70.86)	2100 (82.6)	2300 (90.55)	2500 (98.43)	2800 (110.2)	1500 (59.05)	1800 (70.86)	2100 (82.6)	2300 (90.55)	2500 (98.43)	2800 (110.2)																							
Table Size							1250	1650	1650				1250	1650	1650	2000	2000	2400	1250	1650	1650	2000	2000	2400	1250	1650	1650	2000	2000	2400	1250	1650	1650	2000	2000	2400	1250	1650	1650	2000	2000	2400	1250	1650	1650	2000	2000	2400																	
							x	x	x				x	x	x	x	x	x	x	x	x	x	x	x	x	x	x	x	x	x	x	x	x	x	x	x	x	x	x	x	x	x	x	x	x	x	x	x																	
Load Capacity	A B C		D E F				6000kg (13200lb)						9000kg (19800lb)						11000kg (24200lb)						13000kg (28600lb)						15000kg (33000lb)						17000kg (37400lb)																												
X-axis Table Travel (Forth And Back)							2230 (87.8")						3230 (127.16")						4230 (166.53")						5230 (205.90")						6230 (245.27")						8230 (324.015")																												
Y-axis Spindle Head Travel (Left And Right)	A B C		D E F				1400 (55.11)	1700 (66.92)	2000 (78.74)				1400 (55.11)	1700 (66.92)	2000 (78.74)	2200 (86.6)	2400 (94.5)	2700 (106.3)	1400 (55.11)	1700 (66.92)	2000 (78.74)	2200 (86.6)	2400 (94.5)	2700 (106.3)	1400 (55.11)	1700 (66.92)	2000 (78.74)	2200 (86.6)	2400 (94.5)	2700 (106.3)	1400 (55.11)	1700 (66.92)	2000 (78.74)	2200 (86.6)	2400 (94.5)	2700 (106.3)	1400 (55.11)	1700 (66.92)	2000 (78.74)	2200 (86.6)	2400 (94.5)	2700 (106.3)																							
Z-axis Spindle Head Travel (Up And Down)													850 (33.46")						700 (27.55")																																														
Distance From Spindle Nose To Table Top																			200-1050 (7.87"-41.34")						200-900 (7.87"-35.43")																																								
Spindle Taper																			ISO 50																																														
Spindle Speed																			20-3200(*35-5200rpm)																																														
No. of spindle speed																			Infinite variable, 2-steps																																														
Rapid Traverse Rate(X)							12000mm/min(472ipm)						12000mm/min(472ipm)						10000mm/min(393ipm)						8000mm/min(315ipm)						7000mm/min(275ipm)						7000mm/min(275ipm)																												
Rapid Traverse Rate(Y,Z)																			12000mm/min(472ipm)																																														
Cutting Feed Rate																			1-5000mm/min(0.1-196ipm)																																														
Minimum Input Increment																			0.001(0.0001")																																														
Main Spindle Motor (Continuous/30min)																			AC 20HP/25HP(*30HP/35HP)																																														
Tool							Tool Magazine Capacity - 30(*40,*50,*60,*90) Tools Max. Tool Length - 350 (13.8")						Tool Selection Method - Shortest path Max. Tool Diameter - ø130(5.11"), (ø200(7.87"))						Tool Shank Shape - MAS403-BT50						Max. Tool Weight - 20kg (44lb)						Tool Pull Stud - MAS-P50T-1																																		
							±0.005/300 (±0.0002"/12") ±0.01(±0.0004")/Full Travel						±0.005/300 (±0.0002"/12") ±0.01(±0.0004")/Full Travel						±0.005/300 (±0.0002"/12") ±0.015(±0.0006")/Full Travel						±0.005/300 (±0.0002"/12") ±0.015(±0.0006")/Full Travel						±0.005/300 (±0.0002"/12") ±0.015(±0.0006")/Full Travel																																		
Repeatability Accuracy																																																																	
Floor Space Requirement (L X W)	A B C		D E F				6130						8130						10130						12130						14130						18730																												
	x		x				x						x						x						x						x						x																												
	4509		4809				5109						5509						5709						6009						6009						6009						6009																						
	(241.3")		(241.3")				(241.3")						(320.1")						(320.1")						(398.81")						(477.55")						(556.30")						(737.4")																						
x		x				x						x						x						x						x						x																													
177.5")		189.3")				201")						217")						225")						237")						177.5")						189.3")						201")						217")						225")						237")					
4139		4439				4739						5139						5339						5639						4139						4439						4739						5139						5339						5639					
(241")		(241")				(241")						(320.1")						(320.1")						(398.81")						(477.55")						(556.30")						(737.4")						(737.4")						(737.4")											
x		x				x						x						x						x						x						x						x						x																	
163")		174.7")				186")						202.32")						210.20")						222")						163")						174.7")						186")						202.32")						210.20")						222")					
Overall Machine Height (From Base Bottom)																																																																	
Machine Net Weight (Kg(Lb))	A B C		D E F				18500						23500						29000						33500						37000						48000																												
	x		x				x						x						x						x						x						x																												
17500		18950				20300						23000						25000						29000						31500						28500						35000						40000						47500						52000					
(38500)		(41690)				(44680)						(50600)						(52800)						(55000)						(63800)						(67100)						(88300)						(110440)						(114400)						(136400)					
Power Supply																																																																	
CNC Controller																																																																	

SV FLOOR SPACE

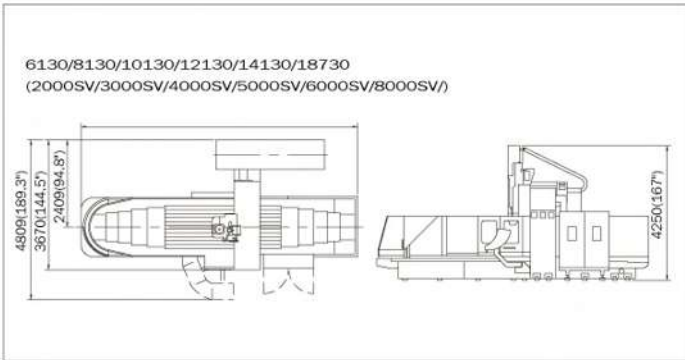

SD FLOOR SPACE

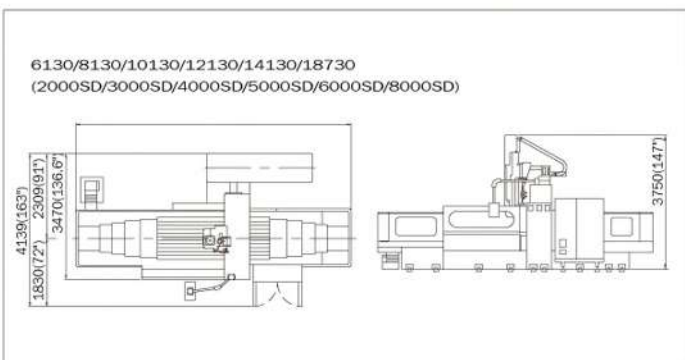

OPTION
 - Design and specification are subject to change without notice. (())Max. tool diameter(without adjacent tools)
 - Distance between two columns A=1500mm(59.05"), B=1800mm(70.86"), C=2100mm(82.6"), D=2300mm(90.55"), E=2500mm(98.43"), F=2800mm(110.2").



DOUBLE-COLUMN TYPE FIVE-FACE MACHINING CENTER



AAC(2-station)



ATC(Horizontal)

MAIN FEATURES

- Based on SV-construction and new features.
- Combines the advantages of machining all 4 sides with angular attachment and machining the top face with vertical spindle head in one set-up.
- AAC(Automatic Attachment Changer) is designed for improving productivity.
- 2-station AAC magazine is located at the rear of table includes an automatic opening door, protecting the attachments from chips and coolant. It can be hoisted up and detached from the table-end; if necessary.
- Since the spindle is driven by a powerful 26KW (35HP) spindle motor and through two-speed transmission by gears, the maximum spindle torque is a powerful 84 kgf-m (606 ft-lbs), allowing heavy-duty cutting.
- The spindle head is hydraulically clamped to the curvic coupling.
- Tool can be easily unloaded/loaded from the horizontal spindle by operating a foot-switch.
- Horizontal spindle employed high-precision hardened and ground spiral bevel gears that could reduce shocks and noises effectively to ensure running stability
- 22KW/3500rpm angular attachment can be indexed to four positions in 90° increments. It is indexed by the shortest path.
- For complex workpieces, indexing to 72 positions in 5° increment is optional.
- Five-face machining pattern software is standard.

ANGULAR ATTACHMENT

Cutting example (test in the best environment)

Face Mill Cutter	ø125
Work Material	S45C
Spindle Speed (rpm)	400
Cutting Width (mm)	100
Cutting Depth (mm)	5
Feedrate (mm/min)	880
Cutting Capacity (cm ³ /min)	440



Horizontal Cutting



(with various options)

SPECIFICATIONS (with AAC-angular attachment changer)

Unit: mm (inch)

ITEM	KMC-3000SV-H				KMC-4000SV-H				KMC-5000SV-H				KMC-6000SV-H				KMC-8000SV-H															
	C	D	E	F	C	D	E	F	C	D	E	F	C	D	E	F	C	D	E	F												
Distance Between Columns	2100 (82.6")	2300 (90.55")	2500 (98.43")	2800 (110.2")	2100 (82.6")	2300 (90.55")	2500 (98.43")	2800 (110.2")	2100 (82.6")	2300 (90.55")	2500 (98.43")	2800 (110.2")	2100 (82.6")	2300 (90.55")	2500 (98.43")	2800 (110.2")	2100 (82.6")	2300 (90.55")	2500 (98.43")	2800 (110.2")												
Table Size	C	1650 (64.96")	2000 (78.74")	2000 (78.74")	2400 (94.5")	D	1650 (64.96")	2000 (78.74")	2000 (78.74")	2400 (94.5")	E	1650 (64.96")	2000 (78.74")	2000 (78.74")	2400 (94.5")	F	1650 (64.96")	2000 (78.74")	2000 (78.74")	2400 (94.5")												
	D	3000 (118.11")	3000 (118.11")	3000 (118.11")	3000 (118.11")	E	3000 (118.11")	3000 (118.11")	3000 (118.11")	3000 (118.11")	F	3000 (118.11")	3000 (118.11")	3000 (118.11")	3000 (118.11")	3000 (118.11")	3000 (118.11")	3000 (118.11")	3000 (118.11")	3000 (118.11")	3000 (118.11")											
Load Capacity	9000kg (19800lb)				11000kg (24200lb)				13000kg (28600lb)				15000kg (33000lb)				17000kg (37400lb)															
X-axis Table Travel	2630 (103.54")				3630 (142.91")				4630 (182.28")				5630 (221.6")				7630 (300.4")															
Y-axis Spindle Head Travel	1950 (76.77")				2150 (84.64")				2350 (92.51")				2650 (104.3")				1950 (76.77")				2150 (84.64")				2350 (92.51")				2650 (104.3")			
Z-axis Spindle Head Travel	775(30.51")/ 750(29.53")																															
Spindle Taper	ISO 50																															
Spindle Speed	4400rpm(*6000rpm)																															
	3500rpm																															
No. Of Spindle Speed	Infinite variable, 2-steps																															
Rapid Traverse Rate (X,Y,Z)	(12, 12, 12) m/min				(10, 12, 12) m/min				(8, 12, 12) m/min				(7, 12, 12) m/min				(7, 12, 12) m/min															
Main Spindle Motor (Continuous/30min)	AC 22kw/26kw (30HP/35HP)																															
Tool Magazine Capacity	30(*40,*50,*60,*90)																															
Positioning Accuracy	±0.005/300(±0.0002"/12") ±0.01 (±0.0004")/Full Travel				±0.005/300(±0.0002"/12") ±0.015 (±0.0006")/Full Travel				±0.005/300(±0.0002"/12") ±0.015 (±0.0006")/Full Travel				±0.005/300(±0.0002"/12") ±0.015 (±0.0006")/Full Travel				±0.005/300(±0.0002"/12") ±0.015 (±0.0006")/Full Travel															
Repeatability Accuracy	±0.003(±0.0001")																															
Attachment Indexing	90°×4 (*5°×72)																															
Index Repeatability	±3 sec																															

OPTION

- Design and specification are subject to change without notice.
- Distance between columns C=2100mm(82.6"), D=2300mm(90.55"), E=2500mm(98.43"), F=2800mm(110.2")

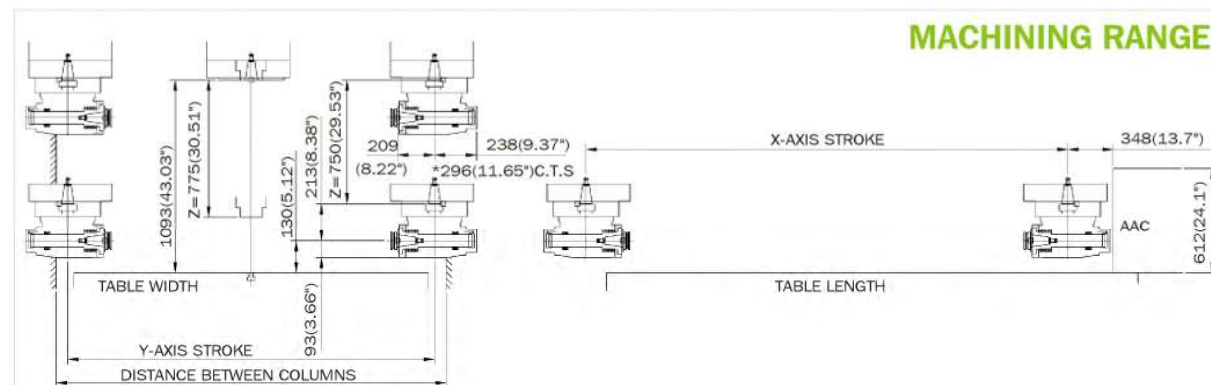

ITEM	KMC-3000SV-H				KMC-4000SV-H				KMC-5000SV-H				KMC-6000SV-H				KMC-8000SV-H			
	C	D	E	F	C	D	E	F	C	D	E	F	C	D	E	F	C	D	E	F
Y-axis stroke	1800 (70.87")	2000 (78.74")	2200 (86.61")	2500 (98.43")	1800 (70.87")	2000 (78.74")	2200 (86.61")	2500 (98.43")	1800 (70.87")	2000 (78.74")	2200 (86.61")	2500 (98.43")	1800 (70.87")	2000 (78.74")	2200 (86.61")	2500 (98.43")	1800 (70.87")	2000 (78.74")	2200 (86.61")	2500 (98.43")
H-mode	2630(103.54")				3630(142.91")				4630(182.28")				5630(221.65")				7630(300.39")			